



BIG Water Temp User Manual



Specification:

- Sensor type: BOSCH 0 280 130 026 (NTC-resistor)
 - Measuring range: -40 - +130°C
 - Measuring resolution: 0.1°C
 - Measuring accuracy: $\pm 4^\circ\text{C}$ (at 100°C) (sensor limited)
 - Operating temperature range (ambient): -40 - +60°C
 - Operating voltage: 12-16Vdc (0.4A max)
 - Overvoltage protection: 39V 15A max (600W) 10/1000 μs
 - Polarity protection: -400Vdc max continuous
 - Internal fuse protection: 2 x F2A
-

Features:

- Peak value memory recall and reset
- Adjustable warning light -40 - +130°C



Connector and wiring:

Pin	Cable colour	Signal
12	RED	+12V
6	BLACK	GND/-
9	WHITE	NTC-1
3	BROWN	NTC-2

Table 1 Connector pins

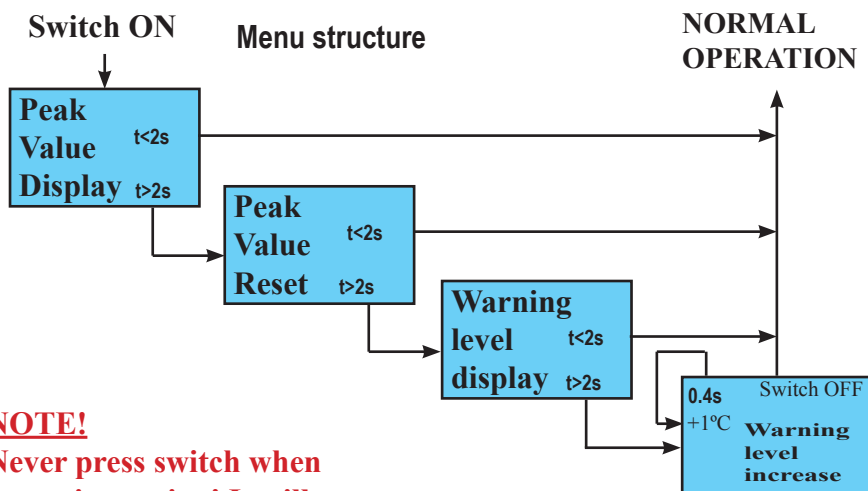

NOTE!
Never press switch when gauge is starting! It will go into calibration mode and needs factory calibration after that!